

ELK-1233 12V, 3.3 Ah

FEATURES

- Valve regulated, non-spillable construction
- UL recognized component
- Two year over-the-counter warranty

APPLICATIONS

- Back-up battery for security alarm systems, fire alarm systems and access control systems
- Emergency lights
- Lighted exit signs
- Uninterruptible power supplies
- Other general purpose use



SPECIFICATIONS

Nominal Voltage	12 Volts
Rated Capacity	3.3 Ah (20 hour rate)
Nominal Capacity (77°F, 25°C)	3.3 Ah
20 hour rate (0.165A)	3.3 Ah
10 hour rate (.31A)	3.1Ah
5 hour rate (.54 A)	2.7 Ah
1 hour rate (1.84 A)	1.84 Ah
Effect of Temperature on Capacity (20 hour rate)	Note: Prolonged exposure to extreme temperatures can have long term effects on battery performance
104°F (40°C)	102%
77°F (25°C)	100%
32°F (0°C)	85%
5°F (-15°C)	65%
Charge Constant Voltage Cycle	14.4V - 14.8V at 77°F (25°C) Initial Charging Current .96A Max
Standby	13.5V - 13.8V at 77°F (25°C)
Weight (Approximate)	2.75 lbs (1.25 kg)
Terminals	F1 Faston Tab (.187")

DIMENSIONS

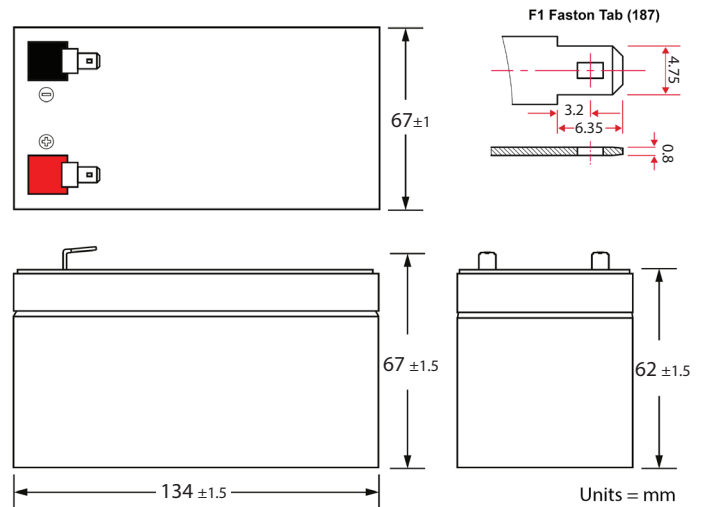

Length	5.28" (134 mm)	Case Height	2.44" (62 mm)
Width	2.64" (67 mm)	Total Height	2.64" (67 mm)

CAPACITY RETENTION CHARACTERISTICS

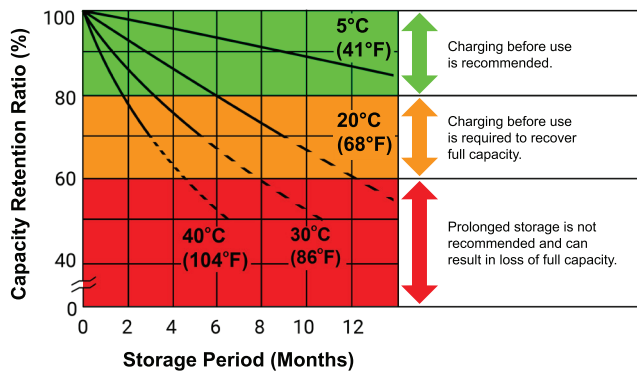

DISCHARGE CHARACTERISTICS (68°F, 20°C)

